

DATE	SYM	REVISION RECORD	ECO	DWN	ENG	MFG
2019-07-22	00	INITIAL RELEASE	0172	JS	EB	SL

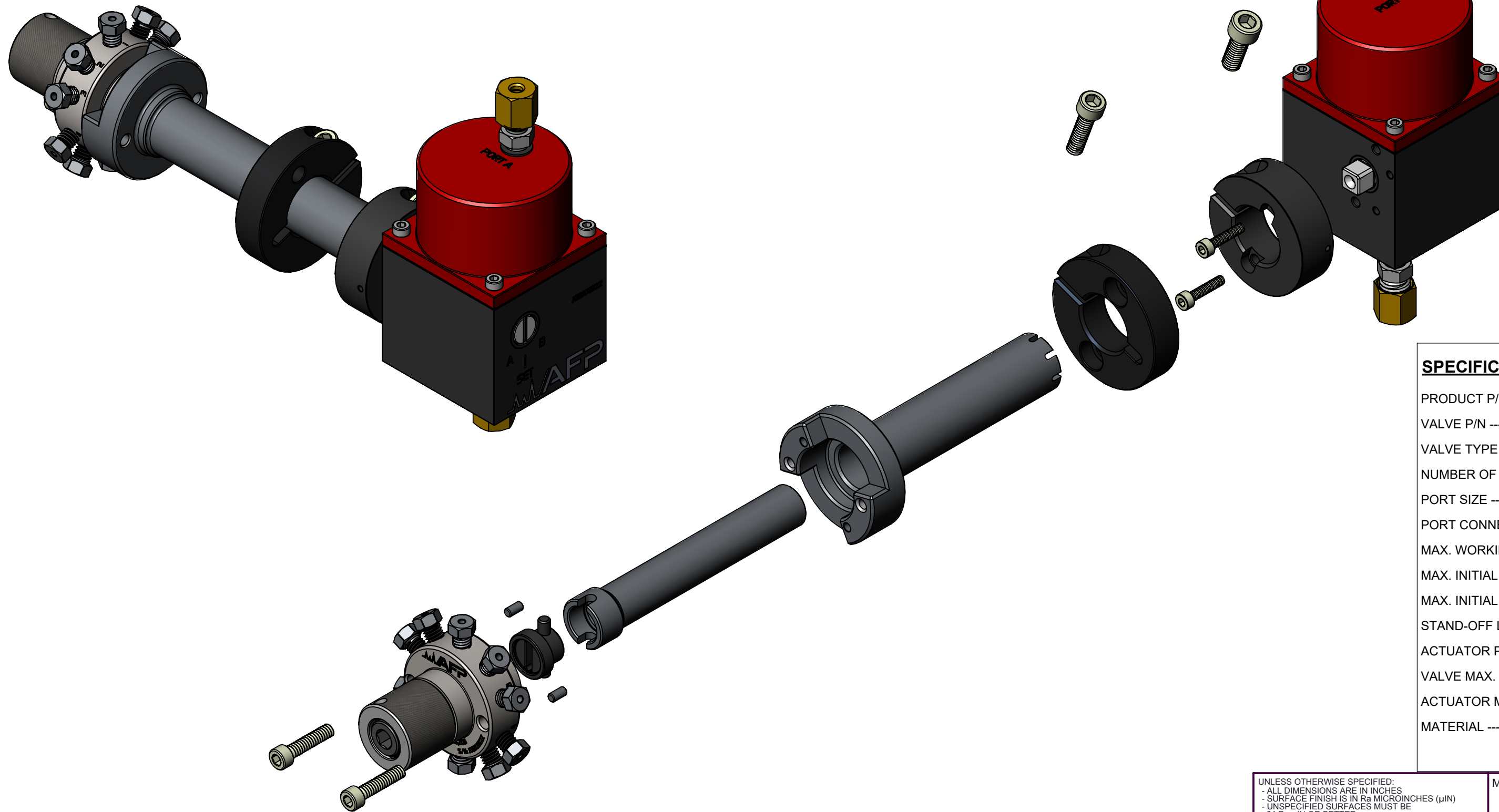
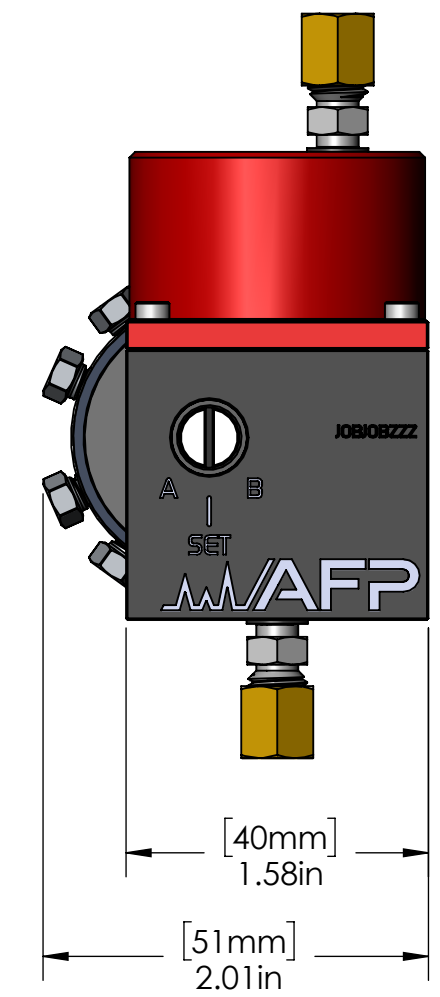
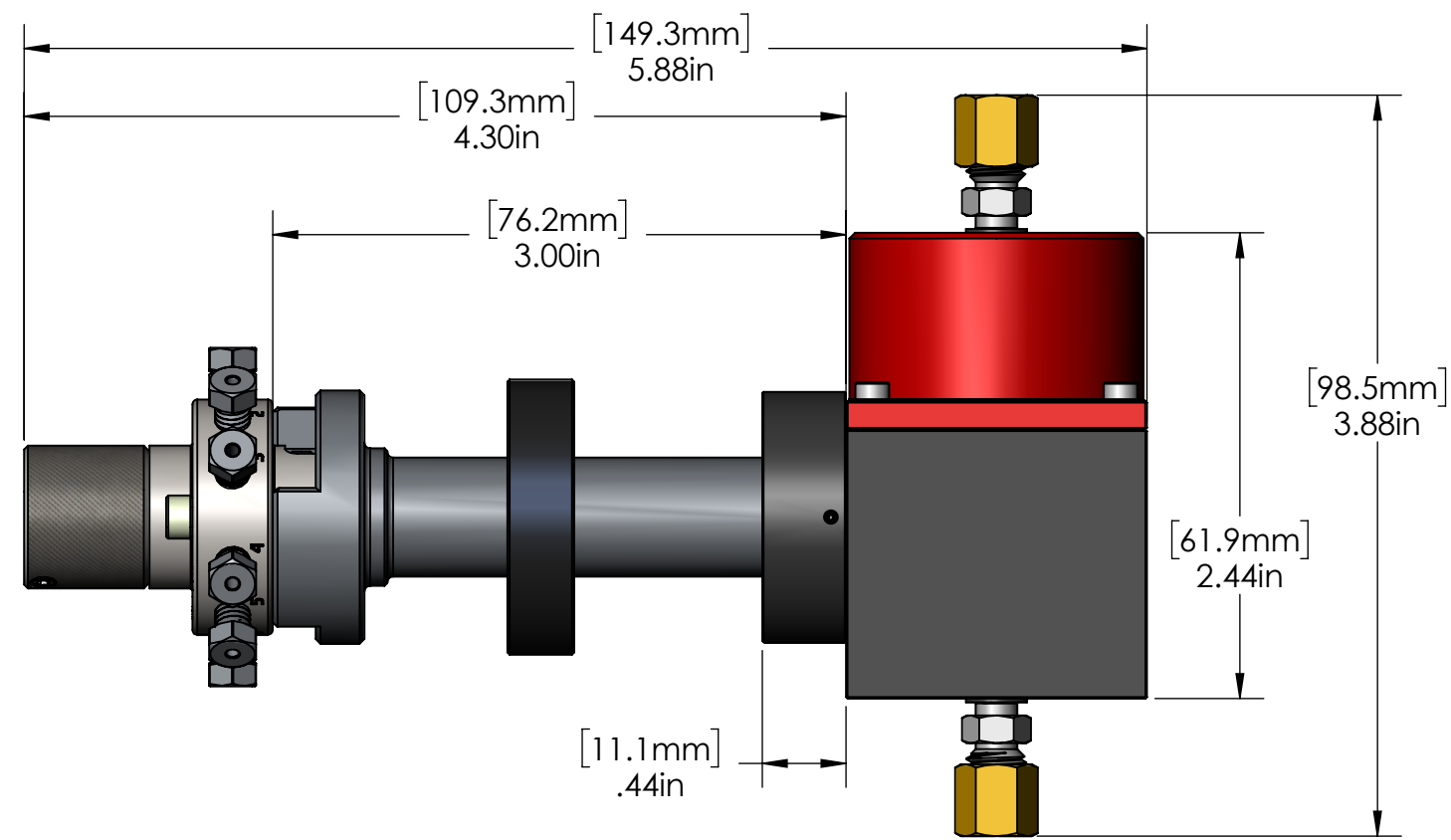

**SPECIFICATIONS:**

PRODUCT P/N .....	MRV10-16R2-0007-3P
VALVE P/N .....	MRV10-16R2-0007
VALVE TYPE .....	HIGH PERFORMANCE GRADE, MEDIUM TEMPERATURE
NUMBER OF PORTS .....	10
PORT SIZE .....	0.025" [0.64 mm]
PORT CONNECTION .....	1/16" [1.6 mm]
MAX. WORKING PRESSURE .....	400 psig [2930 kPa]
MAX. INITIAL LEAK RATE.....	8.5E-10 Atm-cc/s He
MAX. INITIAL PRESSURE DROP.....	2 kPa @ 75 scfm N <sub>2</sub> , max. 1 kPa between any sections
STAND-OFF LENGTH .....	3" [76.2 mm]
ACTUATOR PRESSURE INLET.....	40 psig [275 kPa] min., 80 psig [550 kPa] max.
VALVE MAX. WORKING TEMPERATURE .....	437°F [225°C]
ACTUATOR MAX. WORKING TEMP.....	257°F [125°C]
MATERIAL .....	NITRONIC 60 VALVE STATOR R2 ROTOR TYPE (MODIFIED PEEK)

UNLESS OTHERWISE SPECIFIED:  
 - ALL DIMENSIONS ARE IN INCHES  
 - SURFACE FINISH IS IN Ra MICRONS (µIN)  
 - UNSPECIFIED SURFACES MUST BE 64 Ra µIN OR BETTER  
 - REMOVE ALL BURRS & SHARP EDGES .003-.010  
 - TOLERANCES ARE:  
 .XX ±.010 FRACTIONAL ±1/64"  
 .XXX ±.003 ANGULAR ±5°  
 .XXXX ±.001  
 - UNSPECIFIED INSIDE CORNER RADIUS 0.010 MAX.  
 - REFER TO 3D MODEL FOR DIMENSIONS NOT SHOWN.  
 - TOLERANCE .XX APPLIES  
 - DO NOT SCALE DRAWING

MATERIAL:  
  
 FINISH:  
 MS-1021  
 ACCORDANCE WITH LATEST ASME Y14.5

2659, boul. du Parc Technologique,  
 Québec,  
 Québec, CANADA  
 G1P 4S5  
 Tel.: 418-338-0004  
 Fax: 418-338-2500  
 Email: info@afproducts.ca  
 Web: www.afproducts.ca

DESCRIPTION: MRV10 MPA 3" ASSEMBLY

PROPRIETARY INFORMATION  
 THIS DRAWING IS THE PROPERTY OF APN-AFP INC.  
 IT IS RETURNABLE UPON REQUEST AND MUST NOT BE REPRODUCED  
 OR THE INFORMATION CONTAINED HEREIN TRANSMITTED TO ANY  
 UNAUTHORIZED PERSON OR ORGANIZATION WITHOUT THE  
 WRITTEN CONSENT OF APN-AFP INC.

UNIT	SIZE	DWG. NO.	REV.
IN	C	MRV10-16R2-0007-3P	00
SCALE	1	SHEET 1 OF 2	